



Declaration of Performance No 1488-CPD-0163/W

According to the Regulation EU No 305/2011

DGE02 Sinto ST-VE / DGE12 Sinto ST-VEW / DGE22 Sinto ST-VES

Manufacturer: Tecfi S.p.A. - S.S. Appia, km 193 - 81050 Pastorano (CE), Italia

1 - Intended use	
Product-type:	Metal anchor for use in concrete
Anchor type:	Post-installed rebar connections of the sizes 8 to 32 mm with DGE02 Sinto ST-VE, DGE12 Sinto-ST VEW, DGE22 Sinto-ST VES injection mortar
Technical description of the product:	<ul style="list-style-type: none"> - The DGE02 Sinto ST-VE, DGE12 Sinto ST-VEW, DGE22 Sinto ST-VES are chemical anchors (injection type) which consist of a mortar cartridge equipped with a special mixer and threaded rods measuring from M8 to M24 in (with nut and washer): - Galvanized carbon steel - A4-70, A4-80 stainless steel or high corrosion resistance stainless steel
Specification of the intended use in accordance with the applicable EAD	The anchors are intended to be used for anchorages for which requirements for mechanical resistance and stability and safety in use in the sense of the Basic Requirement 1 (EU) 305/2011 shall be fulfilled and failure of anchorages made with these products would compromise the stability of the works, cause risk to human life and/or lead to considerable economic consequences.
Base material:	<ul style="list-style-type: none"> - The post-installed rebar connections may be used in normal weight concrete of a minimum grade C12/15 and maximum grade C50/60 according to EN 206-1. They may be used in non-carbonated concrete with the allowable chloride content of 0,40 % (Cl 0,40) related to the cement content according to EN 206-1. - Non-cracked concrete: sizes from M8 to M30 and from $\varnothing 8$ to $\varnothing 32$. - Cracked concrete: size M10 to M20.
Installation:	<p>The anchors can be installed in:</p> <ul style="list-style-type: none"> - Dry or wet concrete (use category 1): sizes from M8 to M30 and from $\varnothing 8$ to $\varnothing 32$. - Flooded holes with the exception of seawater (use category 2): sizes from M8 to M30 and from $\varnothing 8$ to $\varnothing 32$. - Downward and horizontal and upwards installation: sizes from M8 to M30 and from $\varnothing 8$ to $\varnothing 32$. - The anchors are suitable for hammer drilled holes, for hollow drill bit and for compressed air drill: sizes from M8 to M30 and from $\varnothing 8$ to $\varnothing 32$.
Loads:	<ul style="list-style-type: none"> - Static and quasi static loads: sizes from M8 to M30 and from $\varnothing 8$ to $\varnothing 32$. - Sismic performance category C1: sizes from M12 to M20. - Sismic performance category C2: sizes from M12 to M16.
Durability:	<p>Structures subject to dry internal conditions.</p> <ul style="list-style-type: none"> - Structures subject to external atmospheric exposure including industrial and marine environment). - Structures subject to permanently damp internal conditions if no particular aggressive conditions exist. <p>Note: Particular aggressive conditions are e.g. permanent, alternating immersion in seawater or the splash zone of seawater, chloride atmosphere of indoor swimming pools or atmosphere with extreme chemical pollution (e.g. in desulphurization plants or road tunnels where de-icing materials are used).</p>
Service temperature:	<p>The anchors may be used in the following temperature range:</p> <ol style="list-style-type: none"> -40°C a +40°C (max. short term temperature +40°C and max. long term temperature +24°C). -40°C to +80°C (max. short term temperature +80°C max. short term temperature +50°C). -40°C to +120°C (max. short term temperature +120°C max. short term temperature +72°C).
Resistenza al fuoco:	No performance declared.
Reazione al fuoco:	The anchor is classified A1

Declaration of Performance No 1488-CPD-0163/W

According to the Regulation EU No 305/2011

DGE02 Sinto ST-VE / DGE12 Sinto ST-VEW / DGE22 Sinto ST-VES

Manufacturer: Tecfi S.p.A. - S.S. Appia, km 193 - 81050 Pastorano (CE), Italia



1 - Intended use	
Information referred to in article 31 of Regulation (EC) No 1907/2006 (REACH):	See MSDS
European Assessment Document:	EAD 330499-01-0601
European Assessment Document:	ETA 10/0102
Technical Assessment Body:	INSTYTUT TECHNIKI BUDOWLANEJ (ITB), ul. Filtrowa, PL 1 00-611 Warszawa, Polonia
Design methods:	<ul style="list-style-type: none"> - Anchorages are designed under the responsibility of an engineer experienced in anchorages and concrete work. - Verifiable calculation notes and drawings are prepared taking into account of the forces to be transmitted. - Design according to EN 1992-1-1. - The actual position of the reinforcement in the existing structure shall be determined.
Assessment and Verification of Constancy of Performance:	EC Certificate No. 1488-CPD-0163/W
Notified Body:	INSTYTUT TECHNIKI BUDOWLANEJ (ITB), ul. Filtrowa, PL 1 00-611 Warszawa, Polonia
Under the system:	1

2 - Anchor's components

2.a: Rebars material

Part	Designation		
	Steel, zinc plated $\geq 5 \mu\text{m}$ according to EN ISO 4042	Stainless steel	Stainless steel with high corrosion resistance (HRC)
Threaded rod	Steel class from 4.8 to 10.9, in accordance with EN ISO 898-1	Material 1.4401/1.4571 in accordance with EN 10088; property class 50, 70 ed 80 (A4-70 ed A4-80) in accordance with EN ISO 3506	Material 1.4529/1.4565/1.4547 in accordance with EN 10088; property class 50, 70 e 80 in accordance with EN ISO 3506
Hexagon nut	Steel class from 4 to 10, in accordance with EN 898-2; corresponding to the material of the threaded rod	Material 1.4401/1.4571 according to EN 10088; property class 50, 70 ed 80 (A4-70 ed A4-80) in accordance with EN ISO 3506	Material 1.4529/1.4565/1.4547 in accordance with EN 10088; property class 50, 70 e 80 in accordance with EN ISO 3506
Washer	Steel in accordance with EN ISO 7089; corresponding to the material of the threaded rod	Material 1.4401/1.4571 according to EN 10088; corresponding to the material of the threaded rod	Material 1.4529/1.4565/1.4547 in accordance with EN 10088; corresponding to the material of the threaded rod

Standard commercial threaded rods (class ≤ 8.8):

- Material and mechanical properties according to the previous table
- Marking of the insertion depth on the threaded bar
- Confirmation of materials and mechanical properties by 3.1 inspection certificate in accordance to EN-10204: 2004

Declaration of Performance No 1488-CPD-0163/W

According to the Regulation EU No 305/2011

DGE02 Sinto ST-VE / DGE12 Sinto ST-VEW / DGE22 Sinto ST-VES

Manufacturer: Tecfi S.p.A. - S.S. Appia, km 193 - 81050 Pastorano (CE), Italia



2 - Anchor's components

2.b: Resin

Injection mortar	Composition
DGE02 SINTO ST-VE, DGE12 SINTO ST-VEW, DGE22 SINTO ST-VES	Additive: quartz
Two component injection mortars	Bonding agent: vinylestere resin styrene free
	Hardener: dibenzoyl peroxide

The cartridge code contains the article code, batch, expiration date, installation procedure, workability time and hardening time in relation to the temperature of the concrete, safety pictograms and storage methods



Mixer - the mixer is suitable for any type of cartridge

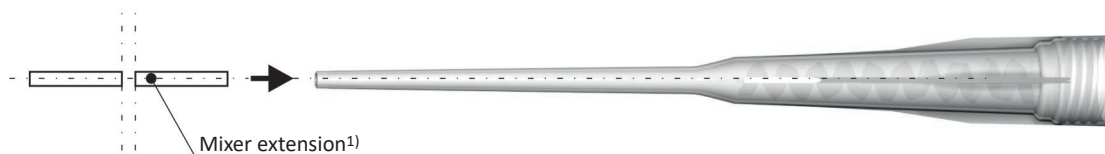

¹)Length variable from 380 [mm] to 1000 [mm]

Declaration of Performance No 1488-CPD-0163/W

According to the Regulation EU No 305/2011

DGE02 Sinto ST-VE / DGE12 Sinto ST-VEW / DGE22 Sinto ST-VES

Manufacturer: Tecfi S.p.A. - S.S. Appia, km 193 - 81050 Pastorano (CE), Italia



3 - Installation

3.a: Installation information:

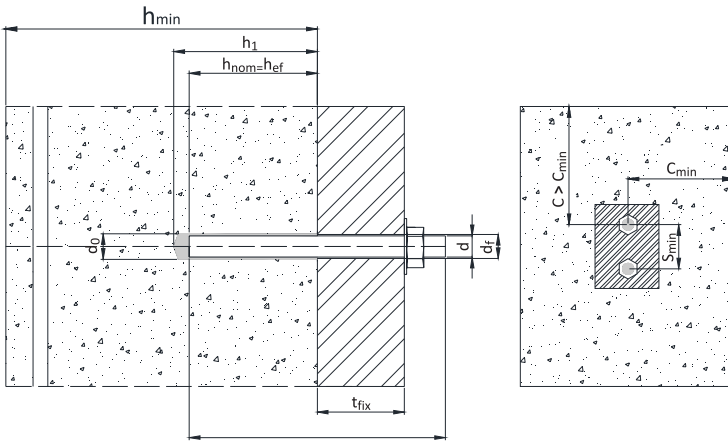

d	Thread diameter
l	Rod's length
d₀	Drill hole diameter
d_f	Diameter of clearance hole in the fixture
t_{fix}	Thickness of fixture
h_{min}	Minimum thickness of concrete member
h₁	Depth of the drill hole
h_{nom}	Overall anchor embedment depth
h_{ef}	Effective anchorage depth
T_{inst}	Required torque moment
S_{min}	Minimum allowable spacing
C_{min}	Minimum allowable edge distance

3.b: Installation data

Size	d [mm]	d ₀ [mm]	d _f [mm]	h ₁ [mm]	h _{min} [mm]	h _{ef,min} [mm]	h _{ef,max} [mm]	T _{inst} [mm]	t _{fix} [mm]	S _{min} [mm]	C _{min} [mm]
M8	8	10	9	h _{ef} +5	h _{ef} +30 ≥100	60	160	10	< 1500	40	40
M10	10	12	12	h _{ef} +5	h _{ef} +30 ≥100	70	200	20	< 1500	50	50
M12	12	14	14	h _{ef} +5	h _{ef} +30 ≥100	80	240	40	< 1500	60	60
M16	16	18	18	h _{ef} +5	h _{ef} +30 ≥100	100	320	80	< 1500	75	75
M20	20	24	22	h _{ef} +5	h _{ef} +2 d ₀	120	400	130	< 1500	100	100
M24	24	28	26	h _{ef} +5	h _{ef} +2 d ₀	145	480	200	< 1500	115	115
M27	27	30	29	h _{ef} +5	h _{ef} +2 d ₀	145	540	250	< 1500	120	120
M30	30	35	33	h _{ef} +5	h _{ef} +2 d ₀	145	600	280	< 1500	140	140

3.c: Installation data

Size	d [mm]	d ₀ [mm]	h ₁ [mm]	h _{min} [mm]	h _{ef,min} [mm]	h _{ef,max} [mm]	S _{min} [mm]	C _{min} [mm]
Ø8	8	10 ¹⁾ 12 ¹⁾	h _{ef} +5	h _{ef} +30 ≥100	50	160	50	50
Ø10	10	12 ¹⁾ 14 ¹⁾	h _{ef} +5	h _{ef} +30 ≥100	70	200	60	60
Ø12	12	14 ¹⁾ 16 ¹⁾	h _{ef} +5	h _{ef} +2 d ₀	80	240	65	65
Ø14	14	18	h _{ef} +5	h _{ef} +2 d ₀	80	280	75	75
Ø16	16	20	h _{ef} +5	h _{ef} +2 d ₀	100	320	80	80
Ø20	20	25	h _{ef} +5	h _{ef} +2 d ₀	120	400	100	100
Ø25	25	30	h _{ef} +5	h _{ef} +2 d ₀	150	500	120	120
Ø28	28	35	h _{ef} +5	h _{ef} +2 d ₀	180	560	140	140
Ø32	30	40	h _{ef} +5	h _{ef} +2 d ₀	200	640	160	160

1) It is possible to use both values



Declaration of Performance No 1488-CPD-0163/W

According to the Regulation EU No 305/2011

DGE02 Sinto ST-VE / DGE12 Sinto ST-VEW / DGE22 Sinto ST-VES

Manufacturer: Tecfi S.p.A. - S.S. Appia, km 193 - 81050 Pastorano (CE), Italia

3.d: DGE02 Sinto-ST-VE Minimum curing time¹⁾

Concrete temperature [°C] ²⁾	Processing time	Minimum curing time ³⁾
-10	1 h 45 min	24 h
-5	1 h 5 min	14 h
0	45 min	7 h
5	25 min	1 h 30 min
10	16 min	1 h
15	11 min	45 min
20	7 min	40 min
25	5 min	35 min
30	3 min	30 min
35	2 min	25 min
40	1 min	20 min

3.e: DGE12 Sinto-ST-VEW Minimum curing time¹⁾

Concrete temperature [°C] ²⁾	Processing time	Minimum curing time ³⁾
-20	2 h	48 h
-15	1 h 30 min	25 h
-10	1 h	15 h
-5	40 min	5 h 15 min
0	25 min	1 h 40 min
5	15 min	1 h 10 min
10	10 min	50 min
15	7 min	35 min
20	5 min	30 min

3.f: DGE22 Sinto-ST-VES Minimum curing time¹⁾

Concrete temperature [°C] ²⁾	Processing time	Minimum curing time ³⁾
20	14 min	1 h
25	11 min	50 min
30	8 min	40 min
35	6 min	30 min
40	4 min	20 min

¹⁾ The minimum time from the end of the mixing to the time when the anchor may be torque or loaded

²⁾ The minimum recommended resin temperature is 5[°C] and the maximum is 30[°C]

³⁾ For wet condition and flooded holes the curing time must be doubled.

Declaration of Performance No 1488-CPD-0163/W

According to the Regulation EU No 305/2011

DGE02 Sinto ST-VE / DGE12 Sinto ST-VEW / DGE22 Sinto ST-VES

Manufacturer: Tecfi S.p.A. - S.S. Appia, km 193 - 81050 Pastorano (CE), Italia



4 - Installation

4.a: Installation procedure for insertion depths up to 300 [mm]

	<p>Drill the hole perpendicularly to the concrete surface with the correct diameter and depth using a rotary percussive machine.</p>
	<p>Clean the hole from drilling dust: the hole shall be cleaned by at least 4 blowing operations, by at least 4 brushing operations followed again by at least 4 blowing operations; before brushing, clean the brush and check if the brush diameter is sufficient.</p>
	<p>For coaxial, peeler and side by side cartridges unscrew the front cup, screw on the mixer and insert the cartridge into the gun. For 300ml size, unscrew the front cup, pull-out the steel closing clip according to the following operation: 1) Insert the mixer in the eye of the plastic extractor; 2) Pull the extractor to unhook the steel closing clip of the foil. In the version without the extractor cut the foil pack. After that screw on the mixer and insert the cartridge in the gun.</p>
	<p>Unscrew the front cap of the cartridge, screw in the mixer and insert the cartridge in the extruder. Before starting to use the cartridge, eject a first part of the product, being sure that the two components are completely mixed. The complete mixing is reached only after that the product, obtained by the mixing of the two components, comes out from the mixer with a uniform color.</p>
	<p>Fill the drill hole uniformly starting from the bottom, in order to avoid entrapment of the air; remove the mixer slowly during the extrusion. Fill the drill hole with a quantity of injection mortar corresponding to 2/3 of the drill hole depth. Insert immediately the rod, marked according to the proper anchorage depth, slowly and with a slight twisting motion, removing excess of injection mortar around the rod. Observe the processing and the curing time before torque or load the anchor. (the rod must be free from oil or other contaminations).</p>

Declaration of Performance No 1488-CPD-0163/W

According to the Regulation EU No 305/2011

DGE02 Sinto ST-VE / DGE12 Sinto ST-VEW / DGE22 Sinto ST-VES

Manufacturer: Tecfi S.p.A. - S.S. Appia, km 193 - 81050 Pastorano (CE), Italia



4 - Installation

4.b: Installation procedure for insertion depths up to 600 [mm]

1		<p>Drill the hole perpendicularly to the concrete surface with the correct diameter and depth using a rotary percussive machine.</p>
2		<p>Clean the hole from drilling dust: the hole shall be cleaned by at least 4 blowing operations, by at least 4 brushing operations followed again by at least 4 brushing operations; before brushing, clean the brush and check if the brush diameter is sufficient.</p>
3		<p>Unscrew the front cap of the cartridge, screw in the mixer and insert the cartridge in the proper pneumatic-pump. Before starting to use the cartridge, eject a first part of the product, being sure that the two components are completely mixed. The complete mixing is reached only after that the product, obtained by the mixing of the two components, comes out from the mixer with an uniform color.</p>
4		<p>Before starting the injection insert the mixer extension and the injection plug (see paragraph 3.3.2.2).</p>
5		<p>Fill the drill hole uniformly starting from the bottom, in order to avoid entrapment of the air; remove the mixer slowly during the extrusion. Fill the drill hole with a quantity of injection mortar corresponding to 2/3 of the drill hole depth. Insert immediately the rod, marked according to the proper anchorage depth, slowly and with a slight twisting motion, removing excess of injection mortar around the rod. Observe the processing and the curing time before torque or load the anchor (the rod must be free from oil or other contaminations)</p>

Declaration of Performance No 1488-CPD-0163/W

According to the Regulation EU No 305/2011

DGE02 Sinto ST-VE / DGE12 Sinto ST-VEW / DGE22 Sinto ST-VES

Manufacturer: Tecfi S.p.A. - S.S. Appia, km 193 - 81050 Pastorano (CE), Italia



4 - Installation

4.c: Intrados installation

<p>1</p>	<p>Start injection: Inject from the bottom of the hole using the proper pneumatic-pump. Hold this position during the injection phase.</p>
<p>2</p>	<p>Injection phase: inject the product about 2/3 of the hole depth. During the injection hold this position to assure the correct installation.</p>
<p>3</p>	<p>End injection: remove the injection plug. Insert immediately the rod (turn the rod during the insertion).</p>
<p>4</p>	<p>End installation: to avoid the slipping of the rod during the open time of the product (due to the rod own weight) use a temporary interlocking element (e.g. wedge of wood).</p>



Declaration of Performance No 1488-CPD-0163/W

According to the Regulation EU No 305/2011

DGE02 Sinto ST-VE / DGE12 Sinto ST-VEW / DGE22 Sinto ST-VES

Manufacturer: Tecfi S.p.A. - S.S. Appia, km 193 - 81050 Pastorano (CE), Italia

4 - Installation

4.1: Cleaning tools

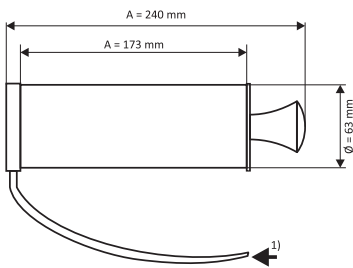

Manual blower pump
(To extend the length of blowing nozzle is it possible to use the mixer extension with the manual blowing pump)



Mechanical air system (compressed air)
The use of the mixer extension is also allowed if using the compressor (compressed air)
- Minimum suitable pressure 6 [bar] at 6 [m3/h].
- Oil free compressed air.
- Recommended air gun with an orifice opening minimum 3,5 [mm] in diameter.

- Standard brush

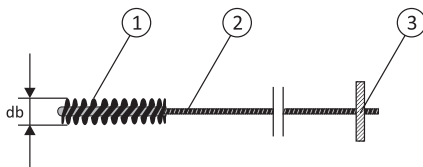

1 - Steel bristles
2 - Steel stem
3 - Wood handle

4.1.1: Standard brush diameter for threaded rods

Threaded rod diameter - d			M8	M10	M12	M16	M20	M24	M27	M30
d_0	Nominal drill hole	[mm]	10	12	14	18	24	28	30	35
d_b	Brush diameter	[mm]	12	14	16	20	26	30	32	37

4.1.2: Standard brush diameter for rebar

Rebar diameter - d			Ø8	Ø10	Ø12	Ø14
d_0	Nominal drill hole	[mm]	10 ¹⁾	12 ¹⁾	12 ¹⁾	14 ¹⁾
d_b	Brush diameter	[mm]	12	14	14	16

1) It is possible to use both values

- Special brush

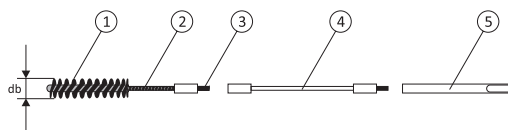

1 - Steel bristles
2 - Steel stem
3 - Threaded connection for drilling tool extension
4 - Special brush extension
5 - Drilling tool connection (SDS connection)

4.1.3: Special brush diameter (mechanical brush) for threaded rods

Threaded rod diameter - d			M16	M20	M24	M27	M30
d_0	Nominal drill hole	[mm]	18	24	28	30	35
d_b	Brush diameter	[mm]	20	26	30	32	37



Declaration of Performance No 1488-CPD-0163/W

According to the Regulation EU No 305/2011

DGE02 Sinto ST-VE / DGE12 Sinto ST-VEW / DGE22 Sinto ST-VES

Manufacturer: Tecfi S.p.A. - S.S. Appia, km 193 - 81050 Pastorano (CE), Italia

4 - Installation

4.1.4: Special brush diameter (mechanical brush) for rebar

Rebar diameter - d			Ø8		Ø10		Ø12		Ø14	Ø16	Ø20	Ø25	Ø28	Ø32
d ₀	Nominal drill hole	[mm]	10 ¹⁾	12 ¹⁾	12 ¹⁾	14 ¹⁾	14 ¹⁾	16 ¹⁾	18	20	25	30	35	40
d ₀	Brush diameter	[mm]	12	14	14	16	16	18	20	22	27	32	37	42

1) It is possible to use both values

4.1.5: Hollow Drill Bit (HDB) for threaded rod

Threaded rod diameter - d			M8		M10		M12		M16	M20	M24	M27	M30
d ₀	Nominal drill hole	[mm]	10		12		14		18	24	28	30	35

4.1.6: Hollow Drill Bit (HDB) for rebar

Rebar diameter-d			Ø8		Ø10		Ø12		Ø14	Ø16	Ø20	Ø25	Ø28
d ₀	Nominal drill hole	[mm]	10 ¹⁾	12 ¹⁾	12 ¹⁾	14 ¹⁾	14 ¹⁾	16 ¹⁾	18	20	25	30	35

1) It is possible to use both values

4.2 - Installation

4.2: Cleaning tools

Installation procedure up to 300 [mm] embedment depth (no overhead installation)

4.2.1 Special installation conditions

4.2.2 Use the mixer extension (assembled on the standard mixer) with the injection plug for installation procedure up to 480 [mm] and overhead installations

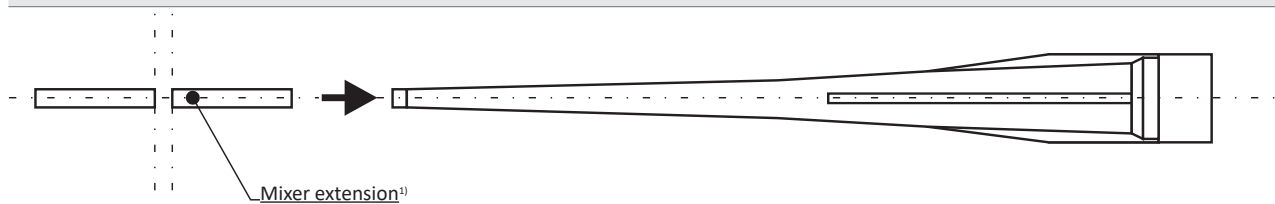

1) Length variable from 380 [mm] to 1000 [mm]

4.2.3 Use the mixer extension (assembled on the standard mixer) with the injection plug for installation procedure up to 480 [mm] and overhead installations

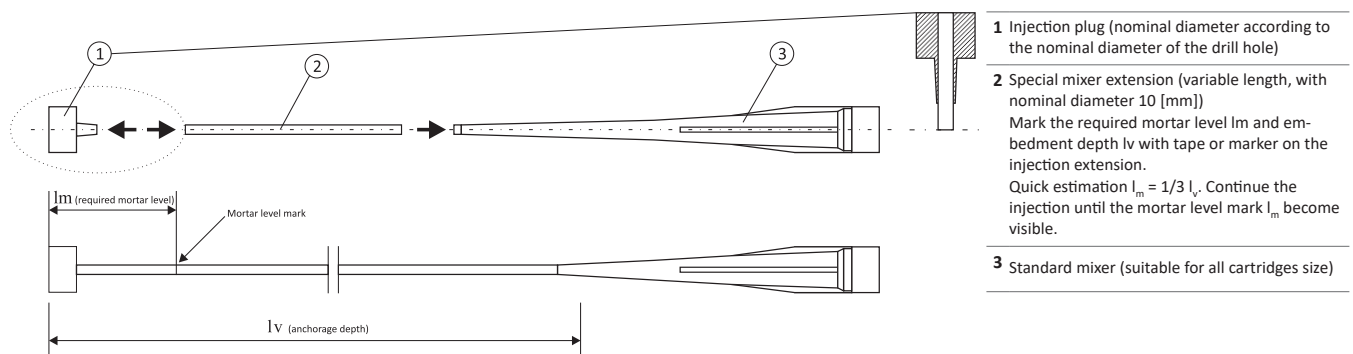

Declaration of Performance No 1488-CPD-0163/W

According to the Regulation EU No 305/2011

DGE02 Sinto ST-VE / DGE12 Sinto ST-VEW / DGE22 Sinto ST-VES

Manufacturer: Tecfi S.p.A. - S.S. Appia, km 193 - 81050 Pastorano (CE), Italia





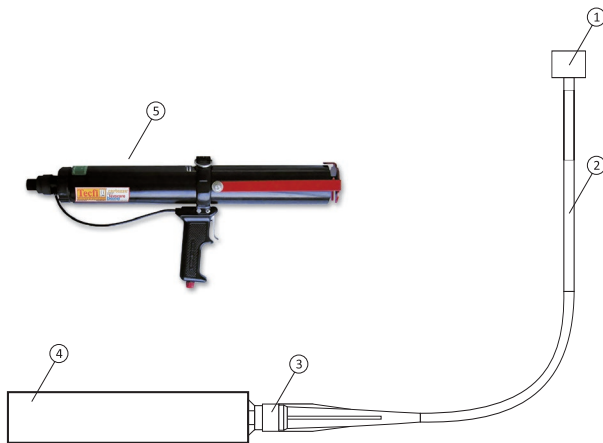

4 - Installation

System assembled



- 1 Injection plug
- 2 Special mixer extension
- 3 Mixer
- 4 Cartridge
- 5 Injection pneumatic pump

3.8: Mortar injection pumps

Pumps (injection dispensers)	Cartridges	Types
DH 03 00 400 	400 ml	Pneumatic ¹⁾
DH 01 00 400 	400 ml	Manual (up to 300 mm anchorage depth)
DH 01 00 345 	345 ml	Manual (up to 300 mm anchorage depth)
DH 01 01 300 	300 ml	Manual (up to 300 mm anchorage depth)

¹⁾ The pneumatic injection pump is recommended for all special applications



Declaration of Performance No 1488-CPD-0163/W

According to the Regulation EU No 305/2011

DGE02 Sinto ST-VE / DGE12 Sinto ST-VEW / DGE22 Sinto ST-VES

Manufacturer: Tecfi S.p.A. - S.S. Appia, km 193 - 81050 Pastorano (CE), Italia

5 - Declared performance according to EAD 330499-01-0601 – Threaded rods

5.a: Combined pull-out and concrete cone failure to tension load in non-cracked concrete

Size		M8	M10	M12	M16	M20	M24	M27	M30
Concrete C20/25, temperature range [-40°C ; +40°C]	$\tau_{Rk,ucr}$ [N/mm ²]	16	12	12	12	9,5	9,5	8,0	8,0
Concrete C20/25, temperature range [-40°C ; +80°C]	$\tau_{Rk,ucr}$ [N/mm ²]	11	8,5	8,5	8,5	7,0	7,0	6,0	6,0
Concrete C20/25, temperature range [-40°C ; +120°C]	$\tau_{Rk,ucr}$ [N/mm ²]	6,0	4,5	4,5	4,5	4,0	4,0	3,0	3,0
Increasing factor for C30/37	ψ_c C30/37					1,15			
Increasing factor for C40/50	ψ_c C40/50					1,23			
Increasing factor for C50/60	ψ_c C50/60					1,30			
Installation safety factor for use category 1	γ_2					1,00			
Installation safety factor for use category 2	γ_2					1,20			

5.b: Concrete cone failure in non-cracked concrete

Factor for cracked concrete	k[-]	11,0							
Edge distance	$C_{cr,N}$ [mm]	1,5*hef							
Spacing	$S_{cr,N}$ [mm]	3,0*hef							

5.c: Combined pull-out and concrete cone failure to tension load in cracked concrete

Concrete C20/25, temperature range [-40°C ; +40°C]	$\tau_{Rk,ucr}$ [N/mm ²]	NPD	9,0	9,0	9,0	6,5	NPD	NPD	NPD
Concrete C20/25, temperature range [-40°C ; +80°C]	$\tau_{Rk,ucr}$ [N/mm ²]	NPD	6,5	6,5	6,5	4,5	NPD	NPD	NPD
Concrete C20/25, temperature range [-40°C ; +120°C]	$\tau_{Rk,ucr}$ [N/mm ²]	NPD	3,5	3,5	3,5	2,5	NPD	NPD	NPD
Increasing factor for C30/37	ψ_c C30/37	1,12							
Increasing factor for C40/50	ψ_c C40/50	1,23							
Increasing factor for C50/60	ψ_c C50/60	1,30							
Installation safety factor for use category 1	γ_2	1,00							
Installation safety factor for use category 2	γ_2	1,20							

5.d: Splitting failure to tension load

Size		M8	M10	M12	M16	M20	M24	M27	M30
Spacing to ensure the transmission of the characteristic tension load of a single anchor without influence of the distance from the edge, in case of splitting failure (design method A)	$S_{cr,sp}$ [mm]	$2 * C_{cr,Np}$							
Edge distance to ensure the transmission of the characteristic tension load of a single anchor without influence of the spacing, in case of splitting failure (design method A)	$C_{cr,sp}$ [mm]	se $h = h_{min}$							
		$2,5 h_{ef}$		$2,0 h_{ef}$		$1,5 h_{ef}$			
		se $h_{min} < h < 2 h_{min}$							
		<p style="text-align: center;">Interpolated value</p>							
se $h \geq 2 h_{min}$								$C_{cr,Np}$	



Declaration of Performance No 1488-CPD-0163/W

According to the Regulation EU No 305/2011

DGE02 Sinto ST-VE / DGE12 Sinto ST-VEW / DGE22 Sinto ST-VES

Manufacturer: Tecfi S.p.A. - S.S. Appia, km 193 - 81050 Pastorano (CE), Italia

5 - Declared performances according to EAD 330499-01-0601 – rebars

5.e: Steel failure

Size		Ø8	Ø10	Ø12	Ø14	Ø16	Ø20	Ø25	Ø28	Ø32
Characteristic reistence	$N_{Rk,s}$ [N/mm ²]	$A_s * f_{uk}^{1)}$								
Cross section area	A_s [mm ²]	50	79	113	154	201	314	491	616	808
Partial factor	$\gamma_{Ms,N}$ [-]	1,4								

1) f_{uk} must refer to the technical specifications of the rebars

5.f: Combined pull-out and concrete cone failure to tension load in non-cracked concrete

Concrete C20/25, temperature range [-40°C ; +40°C]	$T_{Rk,ucr}$ [N/mm ²]	14	13	13	12	10	9,5	9,5	8,5	7,5
Concrete C20/25, temperature range [-40°C ; +80°C]	$T_{Rk,ucr}$ [N/mm ²]	10	9,5	9,0	9,0	7,5	7,0	7,0	6,0	5,5
Concrete C20/25, temperature range [-40°C ; +120°C]	$T_{Rk,ucr}$ [N/mm ²]	5,5	5,0	5,0	5,0	4,0	4,0	4,0	3,5	3,0
Increasing factor for C30/37	ψ_c C30/37	1,12								
Increasing factor for C40/50	ψ_c C40/50	1,23								
Increasing factor for C50/60	ψ_c C50/60	1,30								
Installation safety factor for use category 1	γ_2	1,00								
Installation safety factor for use category 2	γ_2	1,20								

5.g: Concrete cone failure

Factor for cracked concrete	$k[-]$	7,7								
Edge distance	$C_{cr,N}$ [mm]	1,5*hef								
Spacing	$S_{cr,N}$ [mm]	3,0*hef								

5.h: Splitting failure to tension load

Spacing to ensure the transmission of the characteristic tension load of a single anchor without influence of the distance from the edge, in case of splitting failure (design method A)	$S_{cr,sp}$ [mm]	$2 * C_{cr,Np}$								
Edge distance to ensure the transmission of the characteristic tension load of a single anchor without influence of the spacing, in case of splitting failure (design method A)	$C_{cr,sp}$ [mm]	<div style="text-align: center;"> <p>se $h = h_{min}$</p> <p>2,5 h_{ef} 2,0 h_{ef} 1,5 h_{ef}</p> <p>se $h_{min} < h < 2 h_{min}$</p> <p>Interpolated value</p> <p>se $h \geq 2 h_{min}$</p> <p>$C_{cr,Np}$</p> </div>								



Declaration of Performance No 1488-CPD-0163/W

According to the Regulation EU No 305/2011

DGE02 Sinto ST-VE / DGE12 Sinto ST-VEW / DGE22 Sinto ST-VES

Manufacturer: Tecfi S.p.A. - S.S. Appia, km 193 - 81050 Pastorano (CE), Italia

5 - Declared performances according to EAD 330499-01-0601 – Threaded rods

5.i: Shear failure without lever arm

Size		M8	M10	M12	M16	M20	M24	M27	M30
Ductility factor	k_y [-]	1,0							

5.j: Concrete pry out failure

Factor k_g	k_g [-]	2,0							
Partial factor	γ_{inst} [-]	1,0							

5.k: Concrete edge failure

Effective length of anchor under shear loading	l_f [-]	$l_f = h_{ef} \text{ e } \leq 8 d_{nom}$							$l_f = h_{ef}$ $e \leq \max(12d_{nom}, 300 \text{ mm})$	
Installation factor	γ_{inst} [-]	1,0								

5 - Declared performances according to EAD 330499-01-0601 – rebars

5.l: Shear failure without lever arm

Size		Ø8	Ø10	Ø12	Ø14	Ø16	Ø20	Ø25	Ø28	Ø32
Characteristic resistance	$V_{Rk,s}^0$	$0,5 * A_s * f_{uk}^{1)}$								
Cross section area	A_s [mm ²]	50	79	113	154	201	314	491	616	808
Partial factor	$\gamma_{Ms,V}^{1)}$	1,5								
Ductility factor	k_y [-]	1,0								

5.m: Shear failure with lever arm

Characteristic resistance	$M_{Rk,s}^0$	$1,2 * W_{el} * f_{uk}^{1)}$								
Cross section area	W_{el} [mm ³]	50	98	170	269	402	785	1534	2155	3217
Partial factor	$\gamma_{Ms,V}^{1)}$	1,5								

¹⁾ f_{uk} must refer to the technical specifications of the rebars

5.n: Concrete pry out failure

Factor k_g	k_g	2,0								
Partial factor	γ_{inst} [-]	1,0								

5.o: Concrete edge failure

Effective length of anchor under shear loading	l_f	$l_f = h_{ef} \text{ e } \leq 8 d_{nom}$							$l_f = h_{ef}$ $e \leq \max(12d_{nom}, 300 \text{ mm})$	
Installation factor	γ_{inst} [-]	1,0								



Declaration of Performance No 1488-CPD-0163/W

According to the Regulation EU No 305/2011

DGE02 Sinto ST-VE / DGE12 Sinto ST-VEW / DGE22 Sinto ST-VES

Manufacturer: Tecfi S.p.A. - S.S. Appia, km 193 - 81050 Pastorano (CE), Italia

5 - Declared performances according to EAD 330499-01-0601 – Threaded rods

Characteristic values tension and shear resistance load for threaded rod for seismic performance category C1

Size		M12	M16	M20
Steel failure for tension load (standard threaded rod 8.8 with elongation after fracture $A \geq 12\%$)	$N_{Rk, seismic}$ [kN]	1,0 x $N_{Rk, s}$		
Resistance for combined pull-out and concrete cone failure, concrete class C20/25, temperature range [-40°C ; +40°C]	$\tau_{Rk, seismic}$ [N/mm ²]	4,2	3,7	3,7
Resistance for combined pull-out and concrete cone failure, concrete class C20/25, temperature range [-40°C ; +80°C]	$\tau_{Rk, seismic}$ [N/mm ²]	3,0	2,7	2,7
Resistance for combined pull-out and concrete cone failure, concrete class C20/25, temperature range [-40°C ; +120°C]	$\tau_{Rk, seismic}$ [N/mm ²]	1,6	1,4	1,4
Increasing factor for concrete C30/37	ψ_c C30/37	1,00		
Increasing factor for concrete C40/50	ψ_c C40/50	1,00		
Increasing factor for concrete C50/60	ψ_c C50/60	1,00		
Steel failure for shear loads without lever arm (standard threaded rod 8.8 with elongation after fracture $A \geq 12\%$)	$V_{Rk, seismic}$ [kN]	25	39	56
Partial factor	$\gamma_{Rk, seismic}$ [kN]	1,5		

5.q: Characteristic values tension and shear resistance load for threaded rod for seismic performance category C2

Size		M12	M16
Steel failure for tension load	$N_{Rk, seismic}$ [kN]	1,0 x $N_{Rk, s}$	
Resistance for combined pull-out and concrete cone failure, concrete class C20/25, temperature range [-40°C ; +40°C]	$\tau_{Rk, seismic}$ [N/mm ²]	1,6	1,7
Resistance for combined pull-out and concrete cone failure, concrete class C20/25, temperature range [-40°C ; +80°C]	$\tau_{Rk, seismic}$ [N/mm ²]	1,2	1,2
Resistance for combined pull-out and concrete cone failure, concrete class C20/25, temperature range [-40°C ; +120°C]	$\tau_{Rk, seismic}$ [N/mm ²]	0,6	0,7
Increasing factor for concrete C30/37	ψ_c C30/37	1,00	
Increasing factor for concrete C40/50	ψ_c C40/50	1,00	
Increasing factor for concrete C50/60	ψ_c C50/60	1,00	
Steel failure for shear loads without lever arm	$V_{Rk, seismic}$ [kN]	$0,53 \times V_{Rk, s}^0$	$0,46 \times V_{Rk, s}^0$
Steel failure for shear loads without lever arm – hot galvanized bars	$V_{Rk, seismic}$ [kN]	$0,35 \times V_{Rk, s}^0$	



Declaration of Performance No 1488-CPD-0163/W

According to the Regulation EU No 305/2011

DGE02 Sinto ST-VE / DGE12 Sinto ST-VEW / DGE22 Sinto ST-VES

Manufacturer: Tecfi S.p.A. - S.S. Appia, km 193 - 81050 Pastorano (CE), Italia

5 - Declared performances according to EAD 330499-01-0601 – Threaded rods

5.r: Displacement under tension loads- non-cracked concrete

Size		M8	M10	M12	M16	M20	M24	M27	M30
Service load ¹⁾	F_{ucr} [kN]	9,6	10,8	14,3	23,8	29,6	42,4	40,4	44,4
Displacement	$\delta_{NO,ucr}$ [mm]	0,30	0,30	0,35	0,35	0,35	0,40	0,40	0,45
	$\delta_{N\infty,ucr}$ [mm]	0,85	0,85	0,85	0,85	0,85	0,85	0,85	0,85

5.s: Displacement under tension loads-cracked concrete

Size		M10	M12	M16	M20
Service load ¹⁾	F_{ucr} [kN]	9,5	14,3	21,4	23,8
Displacement	$\delta_{NO,ucr}$ [mm]	0,50	0,50	0,70	0,60
	$\delta_{N\infty,ucr}$ [mm]	0,85	0,85	0,85	0,85

5.t: Displacement under shear loads-non-cracked concrete

Size		M8	M10	M12	M16	M20	M24	M27	M30
Service load ¹⁾	F_{ucr} [kN]	3,7	5,8	8,4	15,7	24,5	35,3	45,5	55,6
Displacement	$\delta_{VO,ucr}$ [mm]	2,0	2,0	2,0	2,0	2,0	2,0	2,0	2,0
	$\delta_{V\infty,ucr}$ [mm]	3,0	3,0	3,0	3,0	3,0	3,0	3,0	3,0

5.u: Displacement under tension loads- non-cracked concrete

Size		Ø8	Ø10	Ø12	Ø14	Ø16	Ø20	Ø25	Ø28	Ø32
Service load ¹⁾	F_{ucr} [kN]	10,1	13,6	17,2	20,1	23,9	41,2	53,3	64,1	67,3
Displacement	$\delta_{NO,ucr}$ [mm]	0,33	0,33	0,40	0,41	0,42	0,45	0,45	0,47	0,48
	$\delta_{N\infty,ucr}$ [mm]	0,85	0,85	0,85	0,85	0,85	0,85	0,85	0,85	0,85

5.v: Displacement under shear loads-non-cracked concrete

Size		Ø8	Ø10	Ø12	Ø14	Ø16	Ø20	Ø25	Ø28	Ø32
Service load ¹⁾	F_{ucr} [kN]	13,2	20,6	29,6	40,3	52,7	82,3	128,6	161,3	210,6
Displacement	$\delta_{VO,ucr}$ [mm]	2,0	2,0	2,0	2,0	2,0	2,0	2,0	2,0	2,0
	$\delta_{V\infty,ucr}$ [mm]	3,0	3,0	3,0	3,0	3,0	3,0	3,0	3,0	3,0

¹⁾ These values are suitable for each temperature range and categories

6 - Codici articolo

Size	Cartridge type	Item codes
300 ml	Coaxial	DGE 02 00 300
400 ml	Coaxial	DGE 02 00 400
400 ml	Coaxial	DGE 12 00 400
400 ml	Coaxial	DGE 22 00 400



Declaration of Performance No 1488-CPD-0163/W

According to the Regulation EU No 305/2011

DGE02 Sinto ST-VE / DGE12 Sinto ST-VEW / DGE22 Sinto ST-VES

Manufacturer: Tecfi S.p.A. - S.S. Appia, km 193 - 81050 Pastorano (CE), Italia

7 - Label

Tecfi certezze per lavorare meglio
Sistemi di Fissaggio
ISO 9001 ISO 14001

DGE 02
SINTO-ST

RESINA VINILESTERE SENZA STIRENE

SEISMIC FIXING - PERFORMANCE CATEGORY C2-C1

Vinylester Resin styren free
Résine Vinylester sans styrène
Vinylesterharz styrolfrei
Resina Vinilèster sin estireno

ETA 10/0102
CE 1488
Tecfi S.p.A.
DGE02 - Sinto ST-VE
ETA-10/0102-04/01
bonded fasteners for use in concrete
Gefestigt (Ankerbolzen) für ein in Beton
DOP No. 1488-CPR-0163/W

ETA 10/0103
CE 1488
Tecfi S.p.A.
DGE02 - Sinto ST-VE
ETA-10/0103-04/01
bonded fasteners for use in concrete
Gefestigt (Ankerbolzen) für ein in Beton
DOP No. 1488-CPR-0162/W

Warning
Attenzione

Scadenza / Expiry date: DGE 02 00 300 (v.2.00)

300 ml

Tecfi S.p.A. - Strada (Statale) Appia, Km.193,00
81050 Pastorano (CE) - ITALIA
Tel. (+39) 0823.88.33.38 www.tecfi.it

- 5
- 6
- 7
- 8
- 9
- 10
- 11
- 12
- 13
- 14
- 15

- 1 Item Code
- 2 Descriptions
- 3 Cartridge capacity (ml)
- 4 EAN 13 code
- 5 Installation sequence
- 6 Expiring date
- 7 Lot Number
- 8 Warnings
- 9 Danger symbols
- 10 Identification number of the Notified Body
- 11 Last two digits of the year in which the marking was first affixed
- 12 European standard applied and intended use
- 13 DoP number
- 14 Link to DoP
- 15 European Assessment Document's number

The performance of the product identified above is in conformity with the set of declared performances. This declaration of performance is issued, in accordance with Regulation (EU) No 305/2011, under the sole responsibility of the manufacturer identified above.

Signed for and on behalf of the manufacturer by:

Name and function President Antonio Guarino	Place and date of issue Pastorano, July 22 th 2019	Signature
--	---	----------------------