



Declaration of Performance No 1488-CPD-0162/W

According to the Regulation EU No 305/2011

DGE02 Sinto ST-VE / DGE12 Sinto ST-VEW / DGE22 Sinto ST-VES

Manufacturer: Tecfi S.p.A. - S.S. Appia, km 193 - 81050 Pastorano (CE), Italia

1 - Intended use

Product-type:	Metal anchor for use in concrete
Anchor type:	Post-installed rebar connections of the sizes 8 to 32 mm with DGE02 Sinto ST-VE, DGE12 Sinto-ST VEW, DGE22 Sinto-ST VES injection mortar
Technical description of the product:	The subject of this DoP are the post-installed connections, by anchoring or overlap connection joint consisting of steel reinforcing bars (rebars) in existing structures made of normal weight concrete, using injection mortar DGE02 Sinto ST-VE, DGE12 Sinto ST-VEW, DGE22 Sinto ST-VES in accordance with the regulations for reinforced concrete construction. The design of the post-installed rebar connections shall be done in accordance with EN 1992-1-1 (Eurocode 2).
Specification of the intended use in accordance with the applicable EAD:	The assessment of fitness of the anchor for the intended use in relation to the requirements for mechanical resistance and stability and safety in use in the sense of the Basic Requirements 1 and 4 has been made in accordance with the «Guideline for European Technical Approval of Metal Anchors for use in Concrete», Part 1 «Anchors in general» and Part 5 «Bonded anchors», and EOTA Technical Report 023 «Assessment of post-installed rebar connections».
Base material:	The post-installed rebar connections may be used in normal weight concrete of a minimum grade C12/15 and maximum grade C50/60 according to EN 206-1. They may be used in non-carbonated concrete with the allowable chloride content of 0,40 % (Cl 0,40) related to the cement content according to EN 206-1. Notes: in the case that the surface of the existing structure is carbonated, the carbonated concrete layer must be removed around the installation area of the bar for a surface of diameter $\varnothing + 60$ before installing the new bars. The thickness of concrete to be removed must correspond at least to the minimum concrete cover required by EN 1992-1-1. The previous operation can be omitted if the concrete is not carbonated or if the surface is exposed to dry conditions.
Installation:	<ul style="list-style-type: none"> - Dry or wet concrete (use category 1). - It must not be installed in flooded holes. - Overhead installation is permissible. - Hole drilling by hammer drilling. - Installation of the post-installed rebars shall be done only by suitable trained installer and under supervision on the site. - Check the position of the existing rebars (if the position of existing rebars is not known it shall be determined using a rebar detector suitable for this purpose as well as on the basis of the construction documentation and then marked on the building component for the overlap joint).
Loads	<ul style="list-style-type: none"> - Static and quasi-static loads - Sismic loads - Fire exposition
Durability:	<ul style="list-style-type: none"> - Structures subject to dry internal conditions. - Structures subject to external atmospheric exposure including industrial and marine environment). - Structures subject to permanently damp internal conditions if no particular aggressive conditions exist. <p>Note: Particular aggressive conditions are e.g. permanent, alternating immersion in seawater or the splash zone of seawater, chloride atmosphere of indoor swimming pools or atmosphere with extreme chemical pollution (e.g. in desulphurization plants or road tunnels where de-icing materials are used).</p>
Service temperature::	The anchors may be used in the following temperature range: -40°C to +80°C (max. short term temperature +80°C and max. long term temperature +50°C).
Resistance to fire:	See 4.3
Reaction to fire:	The anchor is classified A1
Information referred to in article 31 of Regulation (EC) No 1907/2006 (REACH):	See MSDS



Declaration of Performance No 1488-CPD-0162/W

According to the Regulation EU No 305/2011

DGE02 Sinto ST-VE / DGE12 Sinto ST-VEW / DGE22 Sinto ST-VES

Manufacturer: Tecfi S.p.A. - S.S. Appia, km 193 - 81050 Pastorano (CE), Italia

1 cont. - Intended use

European Assessment Document:	EAD331522-00-0601 "Post-installed rebar with mortar under seismic action"
European Technical Assessment:	ETA 10/0103
Technical Assessment Body:	INSTYTUT TECHNIKI BUDOWLANEJ (ITB), ul. Filtrowa, PL 1 00-611 Warszawa, Polonia
Design methods:	Anchorage are designed under the responsibility of an engineer experienced in anchorages and concrete work. - Verifiable calculation notes and drawings are prepared taking into account of the forces to be transmitted. - Design according to EN 1992-1-1. - The actual position of the reinforcement in the existing structure shall be determined.
Assessment and Verification of Constancy of Performance:	EC-Certificate No. 1488 CPR-0162/W
Notified Body:	INSTYTUT TECHNIKI BUDOWLANEJ (ITB), ul. Filtrowa 1, PL 00-611 Warszawa, Poland
Under the system:	1

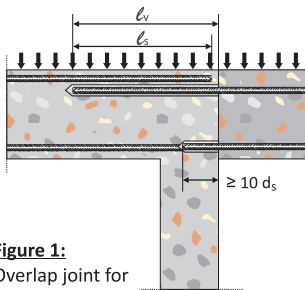

Figure 1:
Overlap joint for rebar connections of slabs and beams

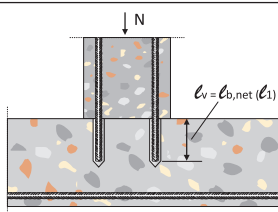

Figure 4:
Rebar connection for components stressed primarily in compression. The rebars are stressed in compression.

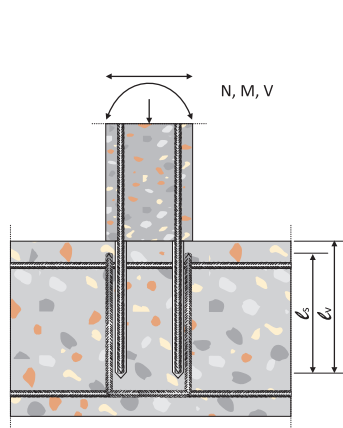

Figure 2:
Overlap joint at a foundation of a column or wall where the rebars are stressed in tension

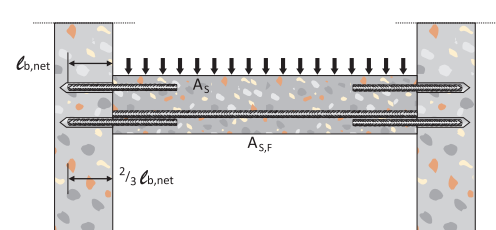

Figure 3:
End anchoring of slabs or beams, designed as simply supported

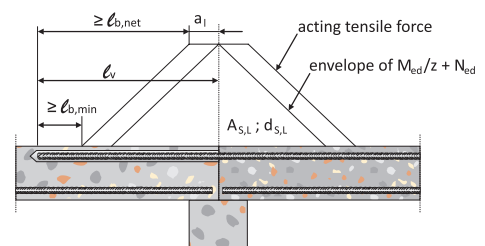

Figure 5:
Anchoring of reinforcement to cover the line of acting tensile force

Note: The transverse reinforcements are not shown in the previous figures. The transverse reinforcements must be present as required by EC2. The transfer of the cut between the old and new element must be designed according to EC2

Declaration of Performance No 1488-CPD-0162/W

According to the Regulation EU No 305/2011

DGE02 Sinto ST-VE / DGE12 Sinto ST-VEW / DGE22 Sinto ST-VES

Manufacturer: Tecfi S.p.A. - S.S. Appia, km 193 - 81050 Pastorano (CE), Italia



2 - Anchor's components

2.1: Rebars material

Product form	Bars and de-coiled rods
Class	Reinforcement bars according to EN1992-1-1:2004+AC:2010 Class B or C bars with f_{yk} k according to EN1992-1-1:2004+AC:2010 $f_{uk} = f_{tk} = k \times f_{yk}$ Rib height $h \leq 0,07 \varnothing$

2.2: Mortar

Injection mortar	Composition
DGE02 Sinto ST-VE / DGE12 Sinto ST-VEW / DGE22 Sinto ST-VES Two-component injection mortar	Additive: quartz Bonding agent: vinyl ester mortar without styrene Catalyst: benzoyl peroxide

The label of cartridge contains the article code, batch, expiration date, installation procedure, workability time and hardening time in relation to the temperature of the concrete, safety pictograms and storage methods



Mixer - the mixer is suitable for any type of cartridge

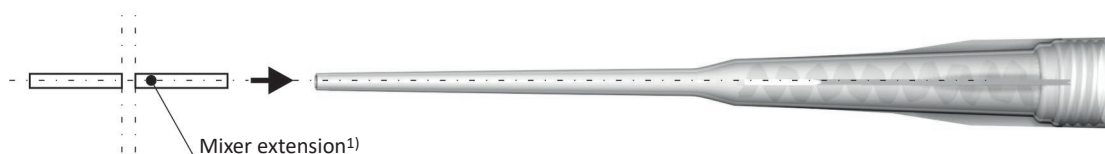

¹)Length variable from 380 [mm] to 1000 [mm]

Declaration of Performance No 1488-CPD-0162/W

According to the Regulation EU No 305/2011

DGE02 Sinto ST-VE / DGE12 Sinto ST-VEW / DGE22 Sinto ST-VES

Manufacturer: Tecfi S.p.A. - S.S. Appia, km 193 - 81050 Pastorano (CE), Italia



3 - Installation

3.1.1: Installation information:

The bar can only transmit axial tensile forces. The transfer of shear forces between the existing and new element must be designed in accordance with EN 1992-1-1.

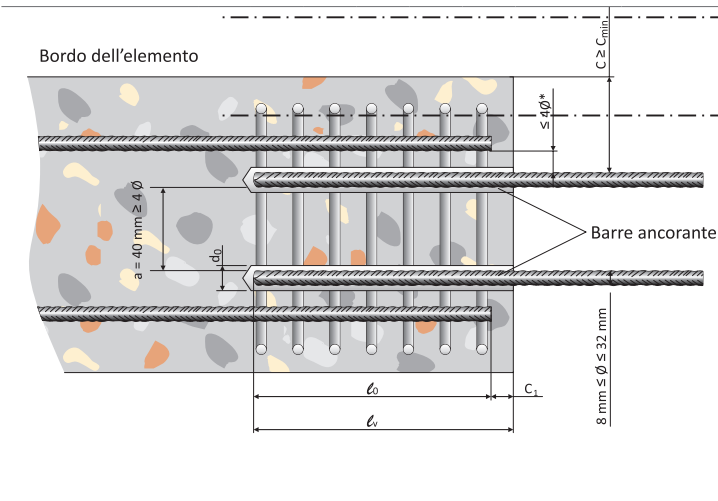

ϕ	Rebar diameter
d_0	Drill hole diameter
l_0	Overlap length (EN 1992-1-1, clause 8.7.3)
l_v	Effective anchorage depth; $l_v \geq l_0 + c_1$
C	Concrete cover of post-installed rebar
C_{min}	Minimum concrete cover (EN 1992-1-1, clause 4.4.1.2)
C_1	Concrete cover of the existing rebar
a^1	Distance between overlapping rebars

1) If the relative distance between the post-installed rebars is greater than $4 \cdot \phi$, the overlap length must be increased of the difference between the distance and $4 \cdot \phi$.

3.1.2: Installation data

Rebar diameter [mm]	$\phi 8$	$\phi 10$	$\phi 12$	$\phi 14$	$\phi 16$	$\phi 20$	$\phi 22$	$\phi 25$	$\phi 28$	$\phi 30$	$\phi 32$			
Drill hole diameter [mm]	10 ¹⁾	12 ¹⁾	12 ¹⁾	14 ¹⁾	14 ¹⁾	16 ¹⁾	18	20	25	26	30	35	35	40
Brush diameter [mm]	12	14	14	16	16	18	20	22	27	27	32	37	37	42
Maximum anchorage depth $l_{v, max}$ [mm]	250	400	250	500	250	600	700	800	1000	1000	1000	1000	1000	1000

1) It is possible to use both values

3.1.3: Installation data for seismic application

Rebar diameter [mm]	$\phi 12$	$\phi 14$	$\phi 16$	$\phi 20$	$\phi 22$	$\phi 25$	$\phi 28$	$\phi 30$	$\phi 32$
Drill hole diameter [mm]	16	18	20	25	26	30	35	35	40
Brush diameter [mm]	18	20	22	27	27	32	37	37	42
Maximum anchorage depth $l_{v, max}$ [mm]	600	700	800	1000	1000	1000	1000	1000	1000

3.1.4: Minimum concrete cover without drilling support

Drilling methods	Rebar diameter	C_{min}
Hammer drilling and hollow drilling bit perforation technique	< 25mm	30 mm + 0,06 x $l_v \geq 2 \phi$
	≥ 25 mm	40 mm + 0,06 x $l_v \geq 2 \phi$
Hammer drilling perforation technique with compressed air	< 25mm	50 mm + 0,08 x l_v
	≥ 25 mm	60 mm + 0,08 x $l_v \geq 2 \phi$



Declaration of Performance No 1488-CPD-0162/W

According to the Regulation EU No 305/2011

DGE02 Sinto ST-VE / DGE12 Sinto ST-VEW / DGE22 Sinto ST-VES

Manufacturer: Tecfi S.p.A. - S.S. Appia, km 193 - 81050 Pastorano (CE), Italia

3.1.5: Minimum concrete cover with drilling aid

Drilling methods	Rebar diameter	C _{min}
Hammer drilling and hollow drill bit perforation technique	< 25mm	30 mm + 0,02 x l _v ≥ 2 ∅
	≥ 25mm	40 mm + 0,02 x l _v ≥ 2 ∅
Hammer drilling perforation technique with compressed air	< 25mm	50 mm + 0,02 x l _v
	≥ 25mm	60 mm + 0,02 x l _v ≥ 2 ∅

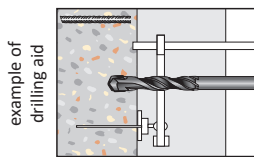

Minimum concrete cover according to **EN1992-1-1:2004+AC:2010**
Must be respected
Minimum gap between two rebars inserted: **a = 40 mm ≥ 4 x ∅**

3.1.6.1: DGE02 Sinto ST-VE minimum curing time¹⁾

Concrete temperature [°C] ²⁾	Processing time	Curing time ³⁾
-5	65 min	780 min
0	45 min	420 min
5	25 min	90 min
10	16 min	60 min
15	11,5 min	45 min
20	7,5 min	40 min
25	5 min	35 min
30	3 min	30 min
35	2 min	25 min
40	1 min	20 min

¹⁾ The minimum time between the end of the mixing and the application of the installation torque or load

²⁾ The minimum recommended temperature of mortar 10[°C]

³⁾ Minimum curing time for dry or wet hole

3.1.6.2: DGE12 Sinto ST-VEW minimum curing time¹⁾

Concrete temperature [°C] ²⁾	Processing time	Curing time ³⁾
-5	40 min	210 min
0	25 min	100 min
5	15 min	70 min
10	10 min	50 min
15	7 min	35 min
20	5 min	30 min

¹⁾ The minimum time between the end of the mixing and the application of the installation torque or load

²⁾ The minimum recommended temperature of mortar 10[°C]

³⁾ Minimum curing time for dry or wet hole

3.1.6.3: DGE22 Sinto ST-VES minimum curing time¹⁾

Concrete temperature [°C] ²⁾	Processing time	Curing time ³⁾
20	14 min	60 min
25	11 min	50 min
30	8 min	40 min
35	6 min	30 min
40	4 min	20 min
45	3 min	20 min
50	2 min	20 min

¹⁾ The minimum time between the end of the mixing and the application of the installation torque or load

²⁾ The minimum recommended temperature of mortar 10[°C]

³⁾ Minimum curing time for dry or wet hole

Declaration of Performance No 1488-CPD-0162/W

According to the Regulation EU No 305/2011

DGE02 Sinto ST-VE / DGE12 Sinto ST-VEW / DGE22 Sinto ST-VES

Manufacturer: Tecfi S.p.A. - S.S. Appia, km 193 - 81050 Pastorano (CE), Italia



3 - Installation

3.2: Installation procedure for depths up to 300 [mm]

	<p>Drill the hole with the correct diameter and depth using a rotary percussive machine, perpedicularly to the concrete surface</p>
	<p>Clean the hole from drilling dust: the hole shall be cleaned by at least 4 blowing operations, by at least 4 brushing operations followed again by at least 4 blowing operations; before brushing, clean the brush and check if the brush diameter is sufficient.</p>
	<p>For coaxial, peeler and side by cartridges unscrew the front cup, screw on the mixer and insert the cartridge into the gun. For 300ml size, unscrew the front cup, pull-out the steel closing clip according to the following operation: 1) Insert the mixer in the eye of the plastic extractor; 2) Pull the extractor to unhook the steel closing clip of the foil. In the version without the extractor cut the foil pack. After that screw on the mixer and insert the cartridge in the gun.</p>
	<p>Unscrew the front cap of the cartridge, screw in the mixer and insert the cartridge in the extruder. Before starting to use the cartridge, eject a first part of the product, being sure that the two components are completely mixed. The complete mixing is reached only after that the product, obtained by the mixing of the two components, comes out from the mixer with a uniform color.</p>
	<p>Fill the drill hole uniformly starting from the bottom, in order to avoid entrapment of the air; remove the mixer slowly during the extrusion. Fill the drill hole with a quantity of injection mortar corresponding to 2/3 of the drill hole depth. Insert immediately the rod, marked according to the proper anchorage depth, slowly and with a slight twisting motion, removing excess of injection mortar around the rod. Observe the processing and the curing time before torque or load the anchor. (the rod must be free from oil or other contaminations).</p>

Declaration of Performance No 1488-CPD-0162/W

According to the Regulation EU No 305/2011

DGE02 Sinto ST-VE / DGE12 Sinto ST-VEW / DGE22 Sinto ST-VES

Manufacturer: Tecfi S.p.A. - S.S. Appia, km 193 - 81050 Pastorano (CE), Italia



3 - Installation

3.3: Installation procedure for depths up to 600 [mm]

1		<p>Drill the hole with the correct diameter and depth using a rotary percussive machine, perpedicularly to the concrete surface</p>
2		<p>Clean the hole from drilling dust: the hole shall be cleaned by at least 4 blowing operations, by at least 4 brushing operations followed again by at least 4 blowing operations; before brushing, clean the brush and check if the brush diameter is sufficient.</p>
3		<p>Unscrew the front cap of the cartridge, screw in the mixer and insert the cartridge in the extruder. Before starting to use the cartridge, eject a first part of the product, being sure that the two components are completely mixed. The complete mixing is reached only after that the product, obtained by the mixing of the two components, comes out from the mixer with an uniform color.</p>
4		<p>Before starting the injection insert the mixer extension and the injection plug (see paragraph 3.3.2.2).</p>
5		<p>Fill the drill hole uniformly starting from the bottom, in order to avoid entrapment of the air; remove the mixer slowly during the extrusion. Fill the drill hole with a quantity of injection mortar corresponding to 2/3 of the drill hole depth. Insert immediately the rod, marked according to the proper anchorage depth, slowly and with a slight twisting motion, removing excess of injection mortar around the rod. Observe the processing and the curing time before torque or load the anchor (the rod must be free from oil or other contaminations)</p>

Declaration of Performance No 1488-CPD-0162/W

According to the Regulation EU No 305/2011

DGE02 Sinto ST-VE / DGE12 Sinto ST-VEW / DGE22 Sinto ST-VES

Manufacturer: Tecfi S.p.A. - S.S. Appia, km 193 - 81050 Pastorano (CE), Italia



3 - Installation

3.4: Intrados installation

1		Start injection: Inject from the bottom of the hole using the proper pneumatic-pump. Hold this position during the injection phase.
2		Injection phase: inject the product about 2/3 of the hole depth. During the injection hold this position to assure the correct installation.
3		End injection: remove the injection plug. Insert immediately the rod (turn the rod during the insertion).
4		End installation: to avoid the slipping of the rod during the open time of the product (due to the rod own weight) use a temporary interlocking element (e.g. wedge of wood).

3.5 - Hollow drill bit specification

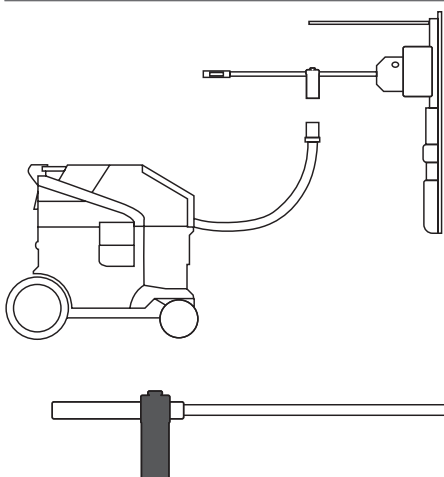

The hollow drill bits can only be used with the hammer drilling mode; this system removes dust during drilling.

The system consists of a kind of hollow point and a vacuum cleaner; a suitable dust extraction system must be used (eg Bosh GAS 35 M AFC or systems with similar performance) It is necessary to switch on the dust extractor before starting to drill

Rebar diameter Ø		Ø8	Ø10	Ø12	Ø14	Ø16	Ø20	Ø25	Ø28	Ø30
d ₀	Drill hole diametre [mm]	10 ¹⁾ 12 ¹⁾	12 ¹⁾ 14 ¹⁾	14 ¹⁾ 16 ¹⁾	18	20	25	30	35	35

1) It is possible to use both values

Declaration of Performance No 1488-CPD-0162/W

According to the Regulation EU No 305/2011

DGE02 Sinto ST-VE / DGE12 Sinto ST-VEW / DGE22 Sinto ST-VES

Manufacturer: Tecfi S.p.A. - S.S. Appia, km 193 - 81050 Pastorano (CE), Italia



3 - Installation

3.6: Cleaning tools

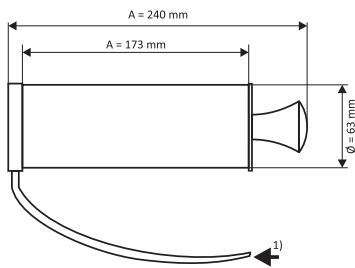

Manual blower pump

(It is possible to use the mixer extension with the manual blower pump)



Mechanical air system (compressed air)

The use of the mixer extension is also allowed if using the compressor (compressed air)

- Minimum suitable pressure 6 [bar] a 6 [m3/h].

- Oil free compressed air.

- Recommended air gun with an orifice opening minimum 3,5 [mm] in diameter.

1) Position for inserting the mixer extension 2)

2) Mixer extension (380 [mm] to 1000 [mm]) with nominal diameter 8 [mm]

Standard brush

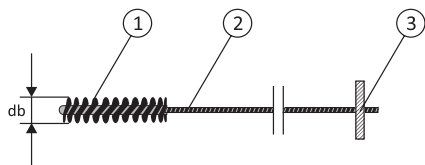

1 – Steel bristles

2 – Steel stem

3 – Wood handle

Rebar diameter Ø		Ø8		Ø10		Ø12		Ø14		Ø16	
d ₀	Drill hole diameter [mm]	10 ¹⁾	12 ¹⁾	12 ¹⁾	14 ¹⁾	14 ¹⁾	16 ¹⁾	18	18	20	20
d _b	Brush diameter [mm]	12	14	14	16	16	18	20	20	22	22

Special brush

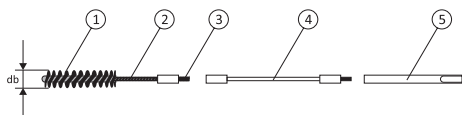

1 – Steel bristles

2 – Steel stem

3 – Threaded connection for drilling tool extension

4 – Special brush extension

5 – Drilling tool connection (SDS)

Rebar diameter Ø		Ø8	Ø10	Ø12	Ø14	Ø16	Ø20	Ø22	Ø25	Ø28	Ø30	Ø32			
d ₀	Drill hole diameter [mm]	10 ¹⁾	12 ¹⁾	12 ¹⁾	14 ¹⁾	14 ¹⁾	16 ¹⁾	18	20	25	26	30	35	35	40
d _b	Brush diameter [mm]	12	14	14	16	16	18	20	22	27	27	32	37	37	42

Declaration of Performance No 1488-CPD-0162/W

According to the Regulation EU No 305/2011

DGE02 Sinto ST-VE / DGE12 Sinto ST-VEW / DGE22 Sinto ST-VES

Manufacturer: Tecfi S.p.A. - S.S. Appia, km 193 - 81050 Pastorano (CE), Italia



3 - Installation

3.7.1 Standard installation conditions:

Installation procedure up to 300 [mm] embedment depth (no overhead installation)

3.7.2 Special installation condition:

3.7.2.1 Use the mixer extension (assembled on the standard mixer) in the installation procedure up to 300 [mm] embedment depth if needed

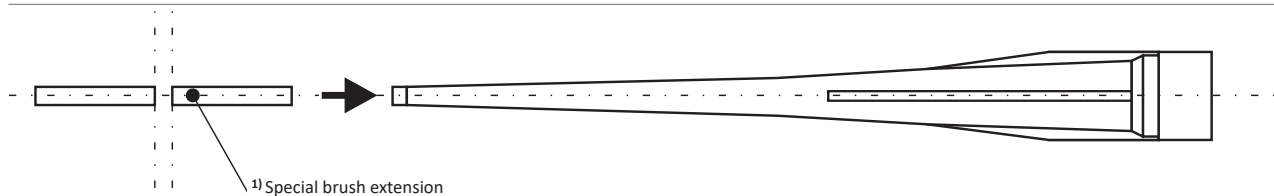

¹⁾ Variable length from 380 [mm] to 1000 [mm]

3.7.2.2 Use the mixer extension (assembled on the standard mixer) with the injection plug for installation procedure up to 600 [mm] and overhead installations

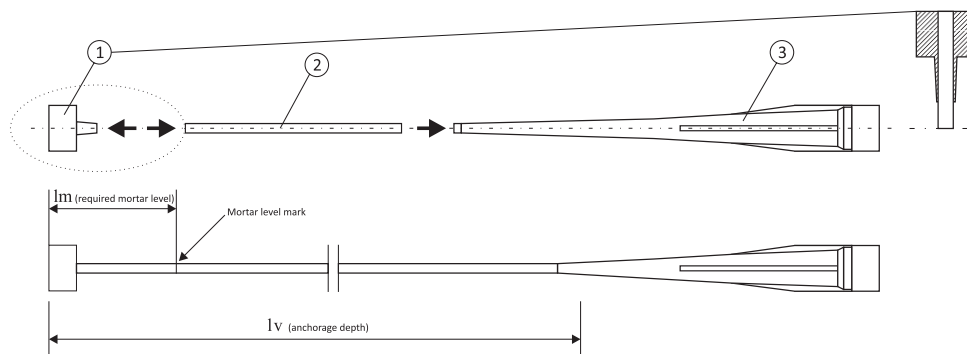

1 – Injection plug (nominal diameter according to the nominal diameter of the drill hole)

2 – Special mixer extension (variable length, with nominal diameter 10 [mm])

Mark the required mortar level l_m and embedment depth l_v with tape or marker on the injection extension.

Quick estimation $l_m = 1/3 l_v$. Continue the injection until the mortar level mark l_m become visible.

3 – Standard mixer (suitable for all cartridges size)

Declaration of Performance No 1488-CPD-0162/W

According to the Regulation EU No 305/2011

DGE02 Sinto ST-VE / DGE12 Sinto ST-VEW / DGE22 Sinto ST-VES

Manufacturer: Tecfi S.p.A. - S.S. Appia, km 193 - 81050 Pastorano (CE), Italia





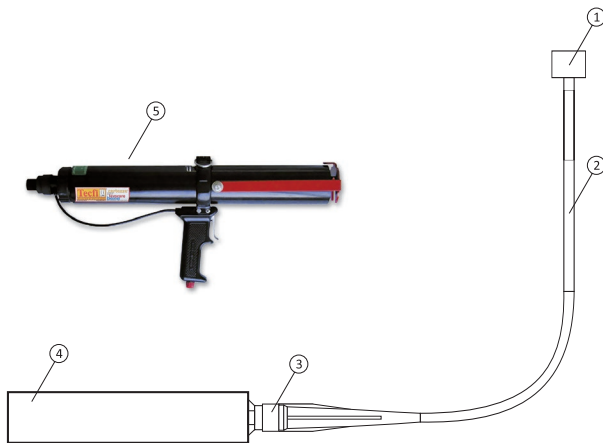

3 - Installation

System assembled



- 1 Injection plug
- 2 Special mixer extension
- 3 Standard mixer
- 4 Cartridge
- 5 Injection pneumatic pump

3.8: Mortar injection pump details

Pump example	Cartridge size	Type
DH 03 00 400 	400 ml	Pneumatic ¹⁾
DH 01 00 400 	400 ml	Manual (up to 300 [mm] embedment depth)
DH 01 00 345 	345 ml	Manual (up to 300 [mm] embedment depth)
DH 01 01 300 	300 ml	Manual (up to 300 [mm] embedment depth)

¹⁾ Pneumatic extruders are recommended for all special installation conditions



Declaration of Performance No 1488-CPD-0162/W

According to the Regulation EU No 305/2011

DGE02 Sinto ST-VE / DGE12 Sinto ST-VEW / DGE22 Sinto ST-VES

Manufacturer: Tecfi S.p.A. - S.S. Appia, km 193 - 81050 Pastorano (CE), Italia

4 - Declared performance according to EAD331522-00-0601

Minimum anchorage length and minimum overlap length for static loads

The minimum anchorage length $l_{b,min}$ and the minimum overlap length $l_{o,min}$ according to EN 1992-1-1:2004+AC:2010 must be amplified with the amplification coefficient α_{lb} .

The design bond strength $f_{bd,PIR}$ is shown in the table; it is obtained by multiplying the bond strength f_{bd} according to EN 1992-1-1:2004+AC:2010 for the factor k_b shown in the table.

4.1.1: Factor α_{lb} for concrete class e drilling method

Concrete class	Drilling method	Rebar size	Factor α_{lb}
C12/15 a C50/60	Hammer drilling Hollow hammer drilling Hammer drilling with compressed air	8 mm to 32 mm	1,0

4.1.2: Bond efficiency factor k_b for concrete class and drilling method

k_b = Hammer drilling Hollow hammer drilling	Concrete class								
	C12/15	C16/20	20/25	C25/30	C30/37	C35/45	C40/50	C45/55	C50/60
Rebar $\varnothing 8$ to $\varnothing 14$	1,00	1,00	1,00	1,00	1,00	1,00	1,00	1,00	1,00
Rebar $\varnothing 16$ to $\varnothing 20$	1,00	1,00	1,00	1,00	1,00	1,00	1,00	1,00	0,93
Rebar $\varnothing 22$	1,00	1,00	1,00	1,00	1,00	1,00	1,00	0,92	0,93
Rebar $\varnothing 24$ to $\varnothing 25$	1,00	1,00	1,00	1,00	1,00	1,00	1,00	0,92	0,86
Rebar $\varnothing 28$	1,00	1,00	1,00	1,00	1,00	1,00	0,91	0,84	0,79
Rebar $\varnothing 30$ to $\varnothing 32$	1,00	1,00	1,00	1,00	0,89	0,80	0,73	0,67	0,63

4.1.3: Design values of the bond strength $f_{bd,PIR}$ according to EN 1992-1-1:2004+AC:2010 for Hammer drilling, Hollow hammer drilling and hammer drilling with compressed air.

Rebar diametr [mm]	Design values of bond strength $f_{bd,PIR}$ ¹⁾								
	C12/15	C16/20	20/25	C25/30	C30/37	C35/45	C40/50	C45/55	C50/60
Rebar $\varnothing 8$ to $\varnothing 14$	1,60	2,00	2,30	2,70	3,00	3,40	3,70	4,00	4,30
Rebar $\varnothing 16$ to $\varnothing 20$	1,60	2,00	2,30	2,70	3,00	3,40	3,70	4,00	4,00
Rebar $\varnothing 22$	1,60	2,00	2,30	2,70	3,00	3,40	3,70	3,70	4,00
Rebar $\varnothing 24$ to $\varnothing 25$	1,60	2,00	2,30	2,70	3,00	3,40	3,70	3,70	3,70
Rebar $\varnothing 28$	1,60	2,00	2,30	2,70	3,00	3,40	3,40	3,40	3,40
Rebar $\varnothing 30$ to $\varnothing 32$	1,60	2,00	2,30	2,70	2,70	2,70	2,70	2,70	2,70

¹⁾ The values provided are valid in conditions of good adherence according to EN 1992-1-1:2004+AC:2010; for all other conditions multiply the values by 0,7

Declaration of Performance No 1488-CPD-0162/W

According to the Regulation EU No 305/2011

DGE02 Sinto ST-VE / DGE12 Sinto ST-VEW / DGE22 Sinto ST-VES

Manufacturer: Tecfi S.p.A. - S.S. Appia, km 193 - 81050 Pastorano (CE), Italia



4 - Performance declared according to all'EAD331522-00-0601

Minimum anchorage length and minimum overlap length for seismic loads

The minimum anchorage length $l_{b,min}$ and minimum overlap length $l_{o,min}$ according to EN 1992-1-1:2004+AC:2010 must be amplified with the amplification coefficient α_{lb} .

The design bond strength $f_{bd,seis}$ is shown in table; it is obtained by multiplying the bond strength f_{bd} according to EN 1992-1-1:2004+AC:2010 for the factor $k_{b,seis}$ shown in table.

For the minimum concrete cover both the contents of the table 3.1.4 and 3.1.5 $c_{min,seis} = 2 \varnothing$ apply.

4.2.1: Bond efficiency factor k_b for concrete class and drilling method

$k_{b,seis}$ = Hammer drilling Hollow hammer drilling	Concrete class								
	C12/15	C16/20	20/25	C25/30	C30/37	C35/45	C40/50	C45/55	C50/60
Rebar $\varnothing 12$ to $\varnothing 25$	1,00	1,00	0,85	0,77	0,68	0,62	0,58	0,53	1,00
Rebar $\varnothing 28$ to $\varnothing 32$	1,00	0,87	0,74	0,67	0,59	0,54	0,50	0,47	0,93

4.2.2: Design values of the bond strength $f_{bd,PIR}$ according to EN 1992-1-1:2004+AC:2010 for Hammer drilling, Hollow hammer drilling and hammer drilling with compressed air.

Rebar diameter [mm]	Design values of bond strength $f_{bd,PIR}$ ¹⁾								
	C12/15	C16/20	20/25	C25/30	C30/37	C35/45	C40/50	C45/55	C50/60
Rebar $\varnothing 12$ to $\varnothing 25$	2,00	2,30	2,30	2,30	2,30	2,30	2,30	2,30	4,30
Rebar $\varnothing 28$ to $\varnothing 32$	2,00	2,00	2,00	2,00	2,00	2,00	2,00	2,00	4,00

¹⁾ The values provided are valid in conditions of good adherence according to EN 1992-1-1:2004+AC:2010; for all other conditions multiply the values by 0,7

4.3 Design values of the bond strength $f_{bd,fi}$ under fire exposure

Design values of bond strength $f_{bd,fi}$ under fire exposure for concrete class C12/15 up to C50/60 for all drilling methods.

Design values of bond strength $f_{bd,fi}$ under fire exposure it must be calculated according to the following formula:

$$f_{bd,fi}(\theta) = k_{fi}(\theta) \cdot f_{bd,PIR} \cdot \frac{\gamma_c}{\gamma_{M,fi}}$$

$$\text{If } 21^\circ\text{C} \leq \theta \leq 271^\circ\text{C: } k_{fi}(\theta) = \frac{17,563 \cdot e^{-0,01\theta}}{f_{bd,PIR} \cdot 4,3} \leq 1,0$$

$$\text{If } \theta > 271^\circ\text{C: } k_{fi}(\theta) = 0$$

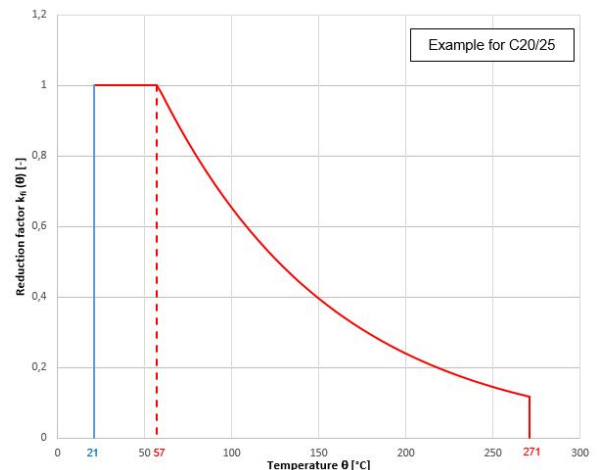

$f_{bd,fi}(\theta)$ = Design values of bond strength under fire exposure

(θ) = Temperature of mortar in °C

$k_{fi}(\theta)$ = Reduction factor under fire exposure

$f_{bd,PIR}$ = Design values of bond strength, in N/mm² considering the concrete class, the rebar diameter, the drilling method and the bonding condition according to EN 1992-1-1

γ_c = Partial safety factor according to EN 1992-1-1:2004+AC2010

$\gamma_{M,fi}$ = Partial safety factor according to EN 1992-1-2:2004+AC2008



Declaration of Performance No 1488-CPD-0162/W
According to the Regulation EU No 305/2011
DGE02 Sinto ST-VE / DGE12 Sinto ST-VEW / DGE22 Sinto ST-VES
Manufacturer: Tecfi S.p.A. - S.S. Appia, km 193 - 81050 Pastorano (CE), Italia

5 - Label

Tecfi certezze per lavorare meglio
Sistemi di Fissaggio
ISO 9001 ISO 14001

DGE 02 SINTO-ST

RESINA VINILESTERE SENZA STIRENE

SEISMIC FIXING - PERFORMANCE CATEGORY C2-C1

Vinylester Resin styren free
Résine Vinylester sans styrène
Vinylesterharz styrolfrei
Resina Vinilèster sin estireno

ETA 10/10102
ETA 10/10103

Tecfi S.p.A.
DGE02 - Sinto ST-VE
EAD 33132-02-001
DoP No. 1488-CPD-0162W

Tecfi S.p.A. - Sinto (Stati) Appia, Km.193,00
81050 Pastorano (CE) - Italia
Tel. (+39) 0823.88.33.38 www.tecfi.it

300 ml

- 1 Item Code
- 2 Descriptions
- 3 Cartridge capacity (ml)
- 4 EAN 13 code
- 5 Installation sequence
- 6 Expiring date
- 7 Lot Number
- 8 Warnings
- 9 Danger symbols
- 10 Identification number of the Notified Body
- 11 Last two digits of the year in which the marking was first affixed
- 12 European standard applied and intended use
- 13 DoP number
- 14 Link to DoP
- 15 European Assessment Document's number

The performance of the product identified above is in conformity with the set of declared performances. This declaration of performance is issued, in accordance with Regulation (EU) No 305/2011, under the sole responsibility of the manufacturer identified above.

Signed for and on behalf of the manufacturer by:

Name and function President Antonio Guarino	Place and date of issue Pastorano, September 14 th 2019	Signature
--	--	----------------------