

HDA-PR	max. $t_{fix}$	$d_f$
HDA-PR M10 x 100/20	20 mm	12 mm
HDA-PR M12 x 125/30	30 mm	14 mm
HDA-PR M12 x 125/50	50 mm	14 mm

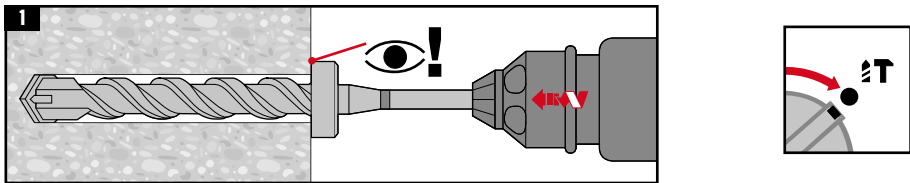

**1.1**

HDA-PR	TE-C (SDS plus)	TE-Y (SDS max)
HDA-PR M10 x 100/20	TE-C-HDA-B 20 x 100	TE-Y-HDA-B 20 x 100
HDA-PR 2M12 x 125/30	TE-C-HDA-B 22 x 125	TE-Y-HDA-B 22 x 125
HDA-PR M12 x 125/50	TE-C-HDA-B 22 x 125	TE-Y-HDA-B 22 x 125

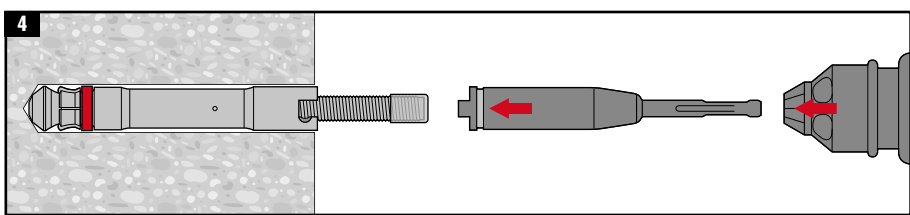
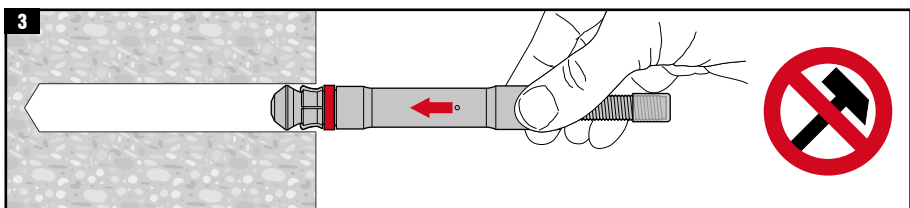
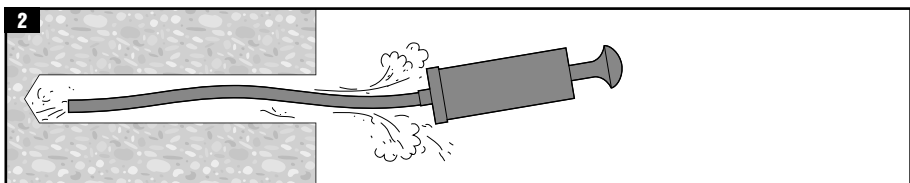

**4.1**

HDA-PR	TE-C (SDS plus)	TE-Y (SDS max)
HDA-PR M10	TE 25, TE 30-A, TE 40	TE 56, TE 60
HDA-PR M12	TE 25, TE 30-A, TE 40	TE 56, TE 60

**4.2**

HDA-PR	TE-C (SDS plus)	TE-Y (SDS max)
HDA-PR M10	TE-C-HDA-ST20-M10	TE-Y-HDA-ST20-M10
HDA-PR M12	TE-C-HDA-ST22-M12	TE-Y-HDA-ST22-M12

**5**

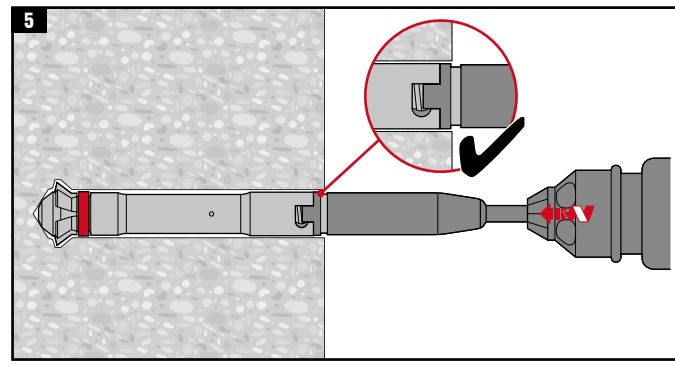

TE	$t_{setting}$
TE 25	10 ... 20 sec (max. 60 sec)
TE 30-A	10 ... 30 sec (max. 60 sec)
TE 40	10 ... 20 sec (max. 30 sec)
TE 56	10 ... 20 sec (max. 60 sec)
TE 60	10 ... 20 sec (max. 60 sec)

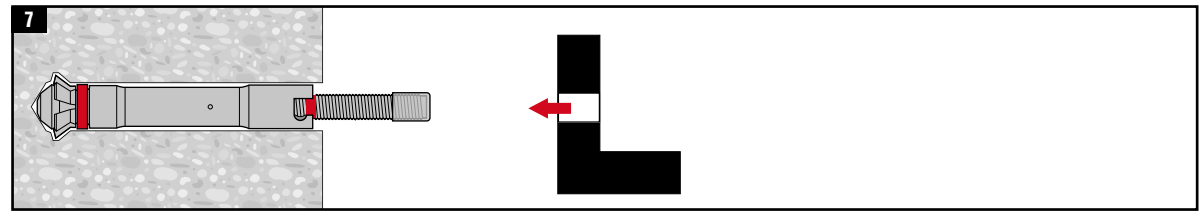
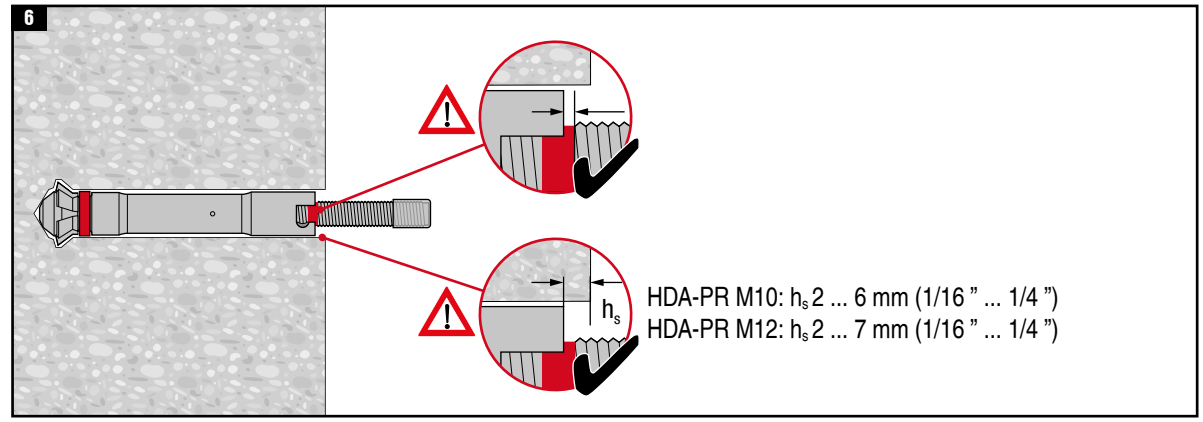

**8**

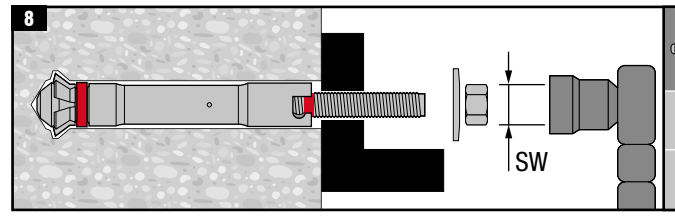

HDA-PR	SW	$T_{inst}$
HDA-PR M10	17	50 Nm (37 ft-lb)
HDA-PR M12	19	80 Nm (59 ft-lb)